

Detecting hidden information using EBIC & RCI



Introduction

Two powerful yet simple analysis techniques for detecting failures in semiconductors are Electron Beam Induced Current (EBIC) and Resistive Contrast Imaging (RCI). Both methods use the electron beam to generate a current inside a sample – the current is then amplified for imaging purposes.

While EBIC uses the current that arises through generation of electron hole pairs in $p-n$ junctions, RCI detects only those electrons remaining or diffusing to metal layers that are usually on top of the semiconductor device.

two MM3A-EM micromanipulators, at least one of which is equipped with a low-current measurement kit (LCMK-EM) and a signal amplifier.

Though mainly used for semiconductor failure analysis, this tool can be used for any application that requires the accurate measurement of low currents.

Fast system setup

Only a few minutes are required to install the system using the SEM/FIB mounting solution provided. The output of the amplifier is then connected

The gain can be varied over a large range to match the needs of both EBIC and RCI signal levels. Currents as low as 1 pA and up to 1 μ A can be measured and visualized.

A separate offset regulator is used to adjust the signal level to the respective input range of the microscope. The upper and lower voltage limits can be adjusted as a surge protection for the video amplifier input.

Imaging using EBIC

EBIC images are created from electrons with energies of more than 5 keV that penetrate through the semiconductor's oxide and metal layers to the $p-n$ junction.

The electron hole pairs that are generated in this process are separated by the diffusion voltage and measured as a current that flows through the probe tip of the manipulator. The current signal is converted to a voltage and fed back to the SEM to obtain a current image of the sample. The light and dark areas in the image indicate $p-n$ junctions (n - and p -wells to the substrate). In the grey regions no current is flowing.

A great advantage of EBIC is the ability to generate electron hole pairs at specific depths by selecting an appropriate electron beam energy. The higher the beam energy, the deeper the penetration into the sample. By taking pictures using different energies, a three-dimensional image of the $p-n$ junctions can be created.

A comparison between the two images on the right, taken at 30 keV and 20 keV electron beam

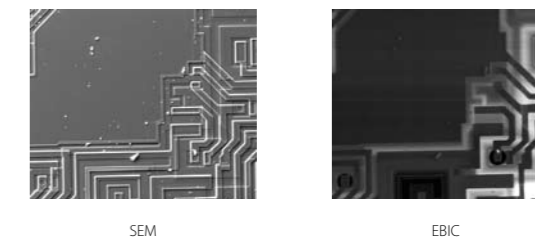
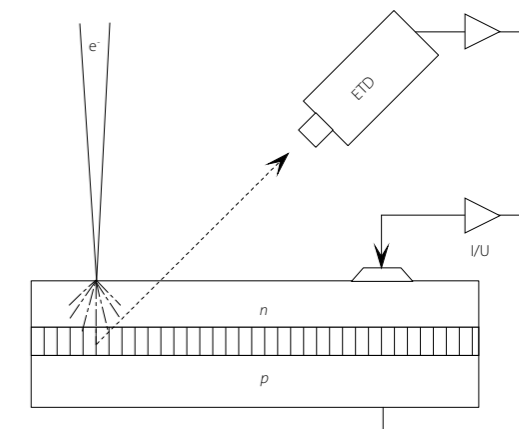

energies, clearly shows that at lower energies less electrons penetrate to the $p-n$ junction, leading to a weaker EBIC signal but more pronounced metal layers.

Offset and amplification are adjusted using the EBIC/RCI amplifier to enhance the details of the area of interest.

Imaging using RCI

RCI differs from EBIC in that the current for the image is generated by electrons diffusing into metal wires that are being contacted by the probe needles of the manipulators. Typically, a contact is made with two wires that are spread over the whole area of interest, like VDD or GND.

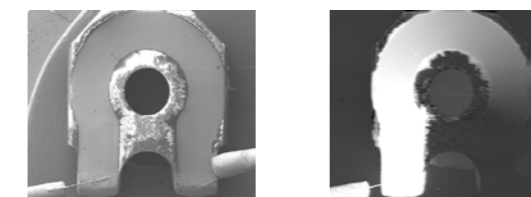

1 M Ω resistance structure showing open current regression

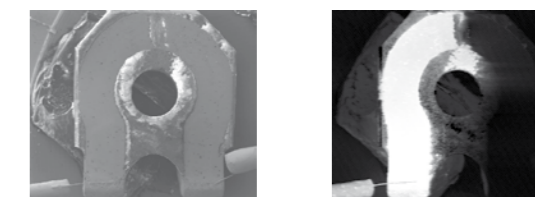

1 M Ω resistance structure showing closed current regression



Seven MM3A-EM micromanipulators installed in an SEM - three are fitted with an LCMK-EM low-current measurement kit

In order to perform EBIC or RCI, one or two stable micromanipulators equipped with highly conductive tips need to be installed into an SEM or FIB. In addition to this, a low-noise current-to-voltage converter that outputs directly to the video input of the microscope is required.

We have designed an easy-to-use EBIC/RCI analysis tool which is compatible with most commercially available SEM's and FIB's. Our system consists of



Low-noise EBIC & RCI amplifier

via BNC cable to the input of the video amplifier or video multiplexer of the microscope. This provides a current image of the sample instead of, or in addition to, the standard SEM image.

EBIC/RCI amplifier

The signal from the manipulators is fed through vacuum compatible triax cables and out of the chamber to the EBIC/RCI amplifier. A fast, low-noise technique is used to convert the current signal to a voltage. A 50 Ω BNC plug is available for output to the microscope's video input port.

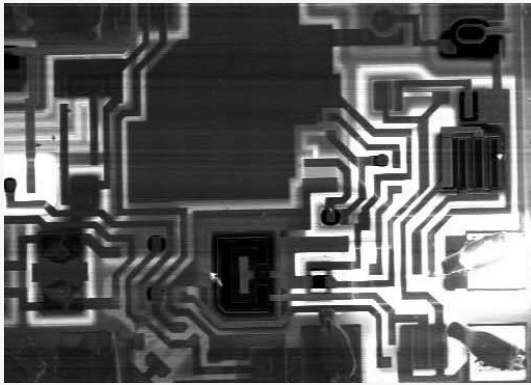

EBIC image of a LM741 operational amplifier (HV = 20 kV)

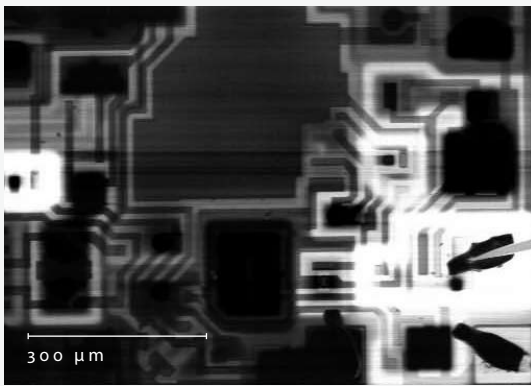

EBIC image of a LM741 operational amplifier (HV = 30 kV)

The result is a resistance image of the current flow from the electron beam position to the contact points. The higher the current, the brighter the image at the electron beam position will be.

The beam energy is usually set below 5 kV to avoid penetration down to the *p-n* junctions. As the current is very small, a low-noise amplifier with high bandwidth is needed to get good images within reasonable time.

Further information

- Contact us at info@nanotechnik.com
- Find your local agent at www.nanotechnik.com

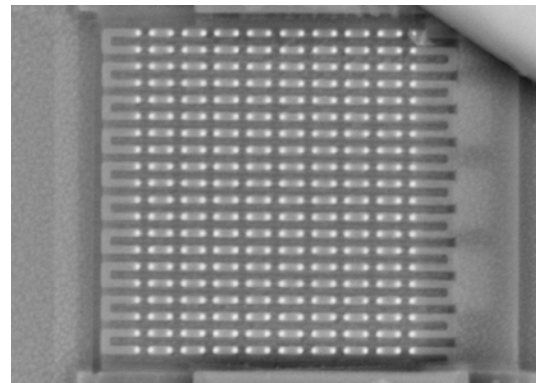

SEM image

Monitoring of capacitive coupled resistance changes in via chains

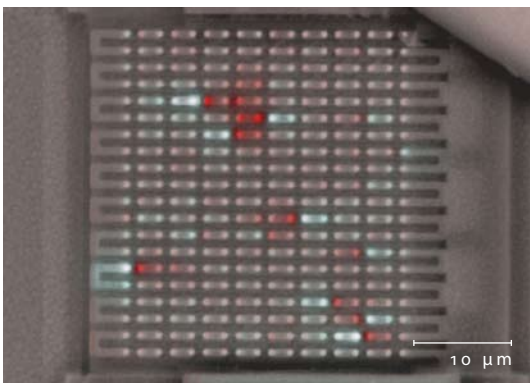

RCI image overlaid on the SEM image

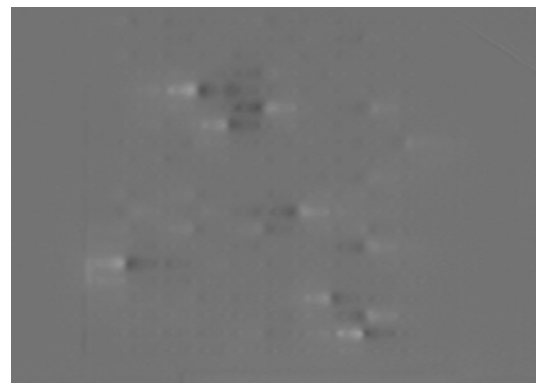

RCI image